



# DG-3, DG-4, DG-5 and VDS Humidity Generators

A range of humidity and dew-point generators offering ease of use and fast response for humidity sensor calibration or precise controlled-humidity generation for laboratory process

- Manual selection, push button or computer control
- -100 to +85 °C dp range capability
- Precision flowmeter or mass flow controller operation
- High stability and repeatability

## The Widest Range of Dew-Point Generators

Although the basic principle of all Michell dew-point generators is the same and depends on volumetric mixing of dry and wet gases, their design and sophistication depends on the needs of the customer and the application. Systems vary from simple manual flowmeter based designs to very sophisticated mass flow, computer controlled generators capable of automatically setting many dew points and logging all measurements. The dew point range of standard generators is up to saturation at room ambient temperature (+20 °C dp). Specially configured dew-point generators for applications requiring precise generation of ultra low or extremely high dew point levels extend the calibration range down to -100 °C dp and up to +85 °C dp.

## Method of Operation

Every Generator in the Michell range works by the divided flow principle. A dry gas source is fed to the generator where it is split into two component parts. One flow stream is saturated by passing it through a volume of pure water at a controlled temperature using a sintered glass bubbler, to give highly efficient saturation. This saturated gas is then diluted with dry gas in prescribed proportions to generate a known humidity level. The generator is calibration verified by three independent methods - firstly, the use of calibrated flowmeters or mass flow controllers; secondly, by reference against Michell's in-house calibration systems and thirdly, in operation by reference against a transfer standard dew-point hygrometer. It is this in-use referencing that



allows the user to maintain a continuous high level of confidence in the generated gas dew point.

## Products

### DG-3

The DG-3 Dewpoint Generator is an uncomplicated single stage, manually set generator with Vernier needle valve flow control. The DG-3 can provide a flow of up to 5 Nlmin<sup>-1</sup> at dew point levels over the range -40 to +20 °C. Used in conjunction with the Michell Dewmet TDH Cooled Mirror Dewpointmeter or a similar transfer standard hygrometer, the DG-3 is ideal for relative humidity calibrations at moderate temperatures or for dew point calibrations in the medium to wet range.

### DG-4

The DG-4 is a two stage push button dew-point generator for operation in the range -75 (-100°C optional) to +20 °C dew point. A bank of pre-set electro-magnetic metering valves automatically selects the wet-dry mixing ratios. The user selects the desired dew point from a keypad. The DG-4 generator provides from 3 to 10 pre-determined dew point levels, which are factory set to customer order. Two stage mixing - saturated gas is mixed with dry gas and then the resultant gas re-mixed with more dry gas - gives extremely high sensitivity of flow and

dew point setting at the lower end of the range, leading to increased stability and repeatability.

## DG-5

Designed with the same primary specification as the DG-4, the DG-5 has the addition of computer control that also works in conjunction with a transfer standard dew-point hygrometer. A computer interface enables a sequence of dew points to be selected automatically. The DG-5 can form the basis of a fully automatic humidity or dew point calibration facility that can be configured not only to set the appropriate dew point levels from the generator, but also to log all necessary operating parameters including data from the humidity sensors under test. PC software for Windows™ is available and can be customised to your specific needs.

## VDS

This state-of-the-art system uses a combination of gas and liquid mass flow controllers, under computer control, to generate any combination of dew points from -100 to +20 °C with complete reliability, flexibility and control. It allows even more precise control over the generated dew point and allows complex performance testing and profiling of humidity sensors (or other humidity sensitive parts or materials) over a range of temperatures and humidities.

## Technical Specifications

### DG-3

Range	-75 to +20 °C dew point
Gas input	7 lmin <sup>-1</sup> air at -75 °C dew point and 0.075 MPa(g)
Gas output	2 to 5 lmin <sup>-1</sup> air at 0.05 MPa(g) and various dew points
Saturator	Sintered glass
Heating	Finned heating element, 30 watts, fan circulation
Power	220/240 or 100/120 V; 50/60 Hz
Storage temp	-40 to +20 °C (with saturators empty)
Operating temp	+5 to +35 °C
Construction	Aluminium case; 19" sub-rack 6U x 350 mm deep
Weight	9 kg (approx)

### DG-4

Range	pre-set over the range -75 to +20 °C dew point
Accuracy	±0.5 °C dew point (displayed)

Gas input	10 lmin <sup>-1</sup> (max) at 0.07 MPa(g) and 1 ppm <sub>v</sub> , -76 °C dew point
Gas output	2 to 5 lmin <sup>-1</sup> at 0.05 MPa(g)
Saturator	Sintered glass
Heating	Finned heating element, 500 watts, fan circulation
Power supply	220/240 V 50 Hz or 100/120 V 60 Hz
Power consumption	750 V-A (max)
Operating temp	+5 to +35 °C
Construction	Aluminium case 553 H x 483 W x 350 D mm
Weight	25 kg (approx)

### DG-5 and VDS

Both of these humidity generators are designed to customer specification - please consult Michell Instruments' Technical Sales Department.

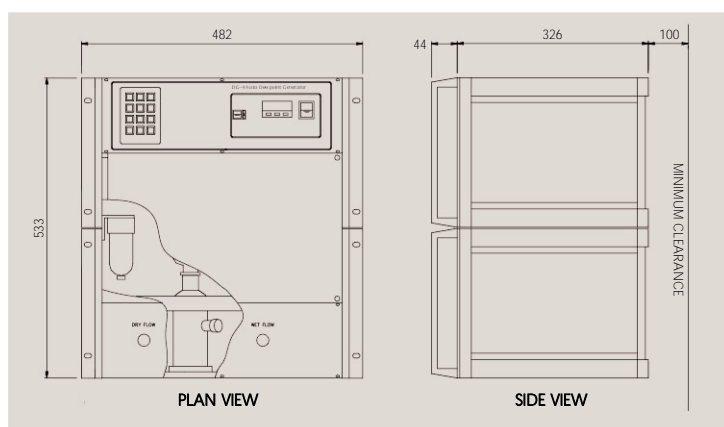

Model shown: DG-4  
Dimensions mm



0179



Q6284

